

# Smart Controller™

MyTemp™ Room by Room Temperature Control and Energy Management

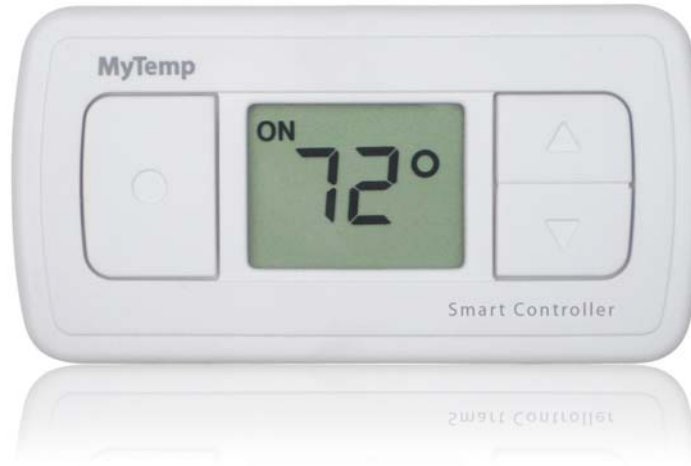

User Manual

*Welcome! Your new Smart Controller is a climate-control breakthrough!*

*Smart Controllers are your key to ultimate comfort, and they are easy to use. In conjunction with the MyTemp™ Climate Control System, your newly installed units allow you to control individual rooms, which creates ideal microclimates you never thought possible from a heating and air-conditioning system.*

*Go ahead, experiment! You'll find instant gratification at your fingertips.*

*Here's to your comfort,*

*The Home Comfort Zones staff*

**Declaration of Conformity**

Model Number: SC-03

Trade Name: Home Comfort Zones

Responsible Party: Home Comfort Zones Inc.

Address: 8239 SW Cirrus Drive, Beaverton, Oregon 97008 U.S.A.

Telephone: (503) 626-2797

This device complies with Part 15 of the FCC rules.

Operation is subject to the following two conditions:

1. This device may not cause harmful interference
2. This device must accept any interference received, including interference that may cause undesired operation.

**Legal and Other Notices**

- The contents of this document are subject to change without prior notice.
- Although the contents of this document have been carefully checked to prevent errors, some may still occur. If you have a question about this manual or if you find an error please contact us.
- Except for personal use, no part of this publication may be reproduced or reprinted without prior written permission from Home Comfort Zones.

Copyright

© Copyright 2007. Home Comfort Zones Inc. All rights reserved.

# Replacing the Batteries

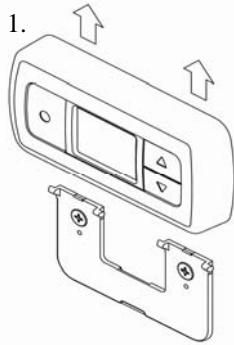

When the **Low Bat** symbol appears on a Smart Controller display, replace the batteries as follows:

1. Lift the Smart Controller off its mounting bracket to remove the Smart Controller from the wall. If using the kickstand rather than mounting bracket, slide the kickstand down and out of its latching mechanism to remove it.

2. Slide off the battery cover and remove the old batteries. Discard the batteries properly. *Never* discard batteries into a fire.

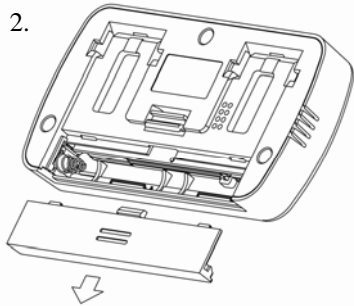

3. Install two new AAA alkaline batteries as shown at right. For efficiency, avoid mixing battery types or using batteries from different manufacturers.

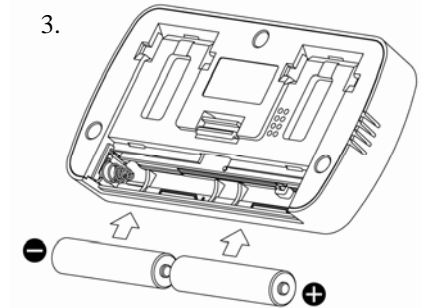

# Your Smart Controller

## **On/Saver/Off Button**

Toggle this button to either place a room **On** for conditioning or in **Saver** mode to save energy. Hold the button for three seconds to turn off conditioning for the room.

## **Increase Temperature**

The up arrow temporarily increases the temperature in the room.

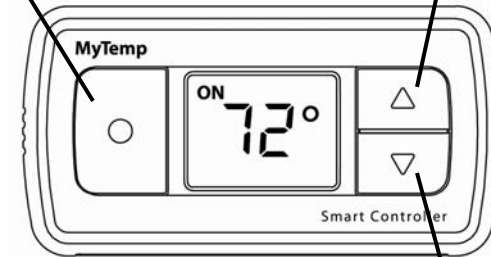

## **Decrease Temperature**

The down arrow temporarily decreases the temperature in the room.

## Smart Controller Room ID Label

Each Smart Controller is linked to a unique room. The room name is identified here.

Kickstand Latching Mechanism

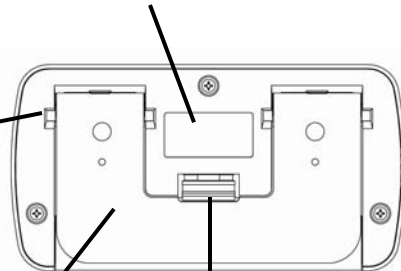

## Integrated Kick-Stand

*Note:* When in place, the kickstand covers the battery cover. See page three.

## Thumb Release

Push up to allow kickstand to swing away from Smart Controller body.

Conditioning is **On** for the room.

Indicates that a temporary temperature was set.

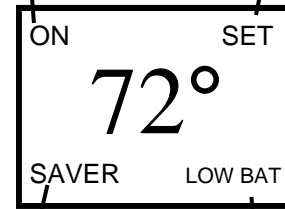

Conditioning is in **Saver** mode for the room.

Indicates that the Smart Controller needs new batteries.

## Positioning Your Smart Controller

*Note:* For the Smart Controller to function properly, your system should be installed and set up by a professional Home Comfort Zones dealer. The installer should have shown you how to set your ideal temperature limits.

The key to your comfort is the proper placement of your Smart Controllers. Smart Controllers are not thermostats; they are the local interface to your MyTemp climate control system and contain temperature sensors. In order for these sensors to function properly, you must consider placement carefully and never remove Smart Controllers from their assigned rooms.

Your HCZ installer helps you determine the proper location for each Smart Controller so that they are in a convenient location away from sources that could artificially influence room temperature. Do not place Smart Controllers:

- Behind doors, in corners, or in other dead-air spaces.
- In direct sunlight or near lamps, appliances, or other sources of radiant heat.
- On outside walls or walls exposed to unconditioned spaces such as garages.
- In the flow path of a supply register, in stairways, or near outside doors.
- On walls where concealed pipes or ductwork can affect the sensor.
- Near sources of electrical interference such as arcing relay contacts or dimmer switches.

As shown on page five, Smart Controllers come with an integrated kickstand that allows you to position them on flat surfaces. To use, press up on the thumb release and pull the kickstand arm away from the Smart Controller body.

## Toggle Between On And Saver Modes

Most thermostats have a setting that allows you to save energy while you are away for an extended period of time. With the MyTemp climate control system, you can now do this for individual rooms with the **Saver** mode.

The **On/Saver/Off** button is a toggle button, which means that you press it to enter **Saver** mode and press it again to return to your normal temperature limits. (**Off** mode is discussed on page nine.)

Any room that goes unused for long periods of time is a candidate for **Saver** mode. You can maintain a room in **Saver** mode until you need it, at which time simply press on the **On/Saver/Off** button to return to the room's normal temperature limits.

In **Saver** mode, the system switches to relaxed temperature limits that allow you to save money. Define these relaxed temperatures using the **Smart Controller Properties** screen on the main display. Refer to the *MyTemp System User Manual* for details about how to set your **Saver** mode temperature limits.

The system default for **Saver** mode is 60°F for heating and 85°F for air conditioning.

On/Saver/Off Button

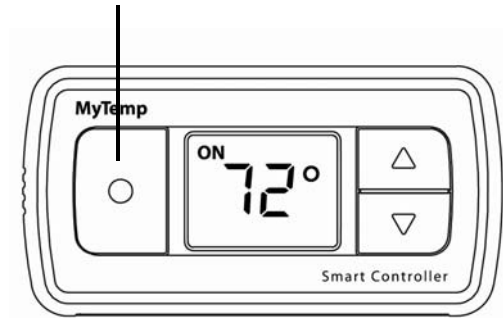

## Temporarily Adjusting Room Temperature

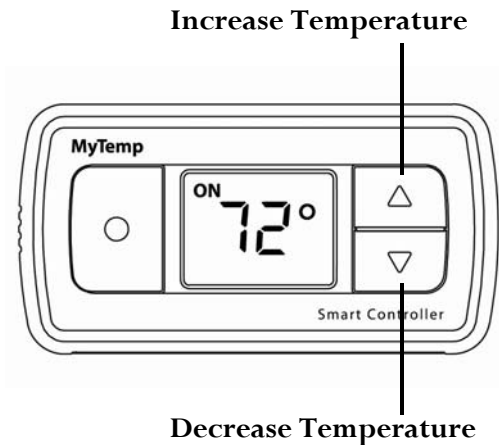

Adjust room temperatures by pressing the up and down buttons on the Smart Controller. This causes the Smart Controller to enter **Set** mode, which means that it is in the process of changing the temperature in the room. The Smart Controller alternately displays the **Set** temperature that you use the up and down arrows to adjust and the current room temperature.

Cancel **Set** mode by pressing the **On/Saver/Off** button.

**Set** mode completes when the current temperature equals the **Set** temperature. By default, this temporary temperature setting lasts for two hours. If you are constantly adjusting a room's temperature, you might consider permanently changing its programmed temperature limits. You can also adjust the duration of temporary settings. Refer to the *MyTemp System User Manual* for details.

## Turning Off Your Smart Controller

You can turn off any Smart Controller at any time by holding down the **On/Saver/Off** button until the display screen goes blank. Turning off a Smart Controller means that the room will not receive conditioning until you turn the Smart Controller on again.

Turn on the Smart Controller by pressing any button on the Smart Controller.

As an example, you might want to turn off conditioning in a given room during a remodel. **Off** mode conserves battery power while you are not using the Smart Controller.

## Potential for Interference

Your Smart Controller has been tested and found to comply with the limits for a class B digital device, pursuant to part 15 of the FCC Rules. These limits are designed to provide reasonable protection against harmful interference in a residential installation. The Smart Controller generates and radiates radio frequency energy and if not installed and used in accordance with instructions, may cause harmful interference to radio communications. However, there is no guarantee that interference will not occur in a particular installation. If the Smart Controller does cause harmful interference to radio or television reception, which can be determined by pressing any button on the Smart Controller, you are encouraged to try to correct the interference by one or more of the following measures:

- Reorient or relocate the receiver antenna for the radio or television.
- Increase the separation between the Smart Controller and the receiver.
- Consult your HCZ dealer.

In order to maintain compliance with FCC regulations, you must not modify any Smart Controller in any way and use only approved batteries. You are cautioned that changes and modifications made to your Smart Controllers could void your authority to operate this equipment.





## Home Comfort Zones

### Company Headquarters

8239 S.W. Cirrus Drive  
Beaverton, Oregon 97008

### Main Phone:

1-800-396-0523

### 24 Hours / 7 Days a Week Support Hotline:

1-877-509-1200



8239 SW Cirrus Drive  
Beaverton, Oregon 97008

**Business Hours:**

8:00AM - 6:00PM (PST)  
Monday - Friday

**Main Phone:**

1-800-396-0523

**After Hours Support**

**24 hours / 7 days a week:**

1-877-509-1200

[www.HomeComfortZones.com](http://www.HomeComfortZones.com)